

VKF1x Series

VKF1x.xxx Butterfly Valves



VKF1x.xxx

ISO 9001 and 14000
REGISTERED FIRM



EAC Conformity (Eurasian Conformity)



ISO 9001:2015
ISO 14001:2015
OHSAS 18001:2007



China RoHS
Hazardous substances table:
<http://www.siemens.com/download?A6V10883536>

Description

VKF1x butterfly valves control the flow of many common gases including air, natural gas, propane, butane, biogas, or FGR.

Features

- Available in swing thru or beveled disk versions
- Full port or reduced port mounting options
- 1-1/4" [DN32] through 8" [DN200] valves available
- Mounts between ANSI #125/#150 or ISO 7005 flanges
- Accommodates flow in either direction
- Valve disk position indication
- Suitable for air, natural gas, propane, butane, or FGR
- Suitable for dry biogas within composition limits
- Maximum media temperature of 356°F [180°C]
- Includes coupling for 10mm D actuator shaft
- Includes bracket for SQM33, SQM40, and SQM45 actuators
- Valve actuator assemblies available (see Technical Instructions VA-3100)

Application

VKF1x butterfly valves control the flow of air, natural gas, propane, butane, biogas, or FGR. Valves are positioned using a rotary actuator.



CAUTION: Valves are not to be used as safety shutoff valves. Valves are designed for throttling service only.

Mounting notes

- Ensure that the relevant safety regulations are complied with
- Mount between flanges conforming to ANSI #125/#150 or ISO 7005-2
- Butterfly valve and actuator can be assembled on site
- No special tools or adjustment required
- The butterfly valve can accommodate flow in either direction (preferred flow direction according to arrow)
- Use flange gaskets that are suitable for the type of gas being used
- Valve opens in the clockwise direction when valve stem is pointing at the observer
- The VKF1 butterfly valves require no maintenance

Mounting flange notes

- When using the valve as a full port valve, any common flange type (butt-weld, slip-on, threaded, etc.) may be used.
- When using the valve as a reduced port valve, consideration should be given to the type of flanges being used. Butt-weld flanges will provide the largest overlap between the sealing surfaces on the valve body and the flanges.
 - **When using a 6" VKF1x.150 valve with 8" flanges, only butt-weld flanges may be used! In addition, 6" full-face gaskets with bolt holes must be used instead of 8" gaskets. The mounting bolts will not pass through the bolt holes in the gasket.**

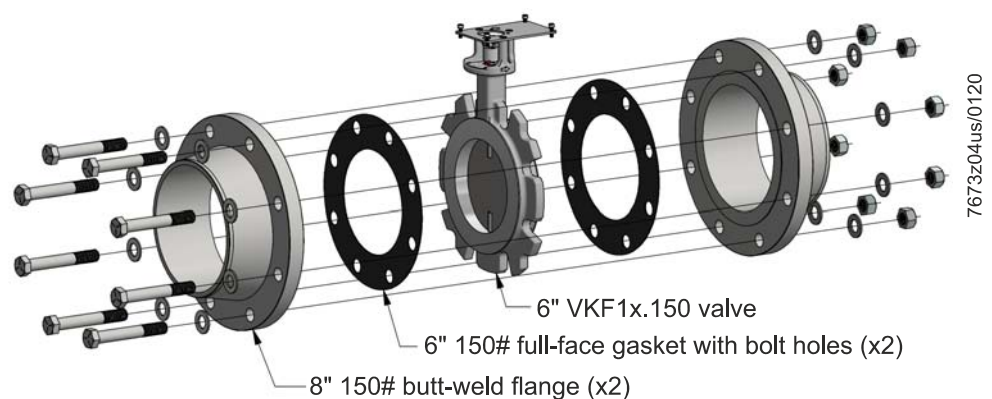

Figure 1. Mounting a 6" VKF1x.150 Valve in a Reduced Port Application

- For all other sizes as a reduced port valve, threaded flanges or slip-on flanges may be used if the valve is properly centered between the flanges.

Part numbers

Table 1. VKF1x.xxx Part Numbers

Part Number	Valve Type	Port Diameter (inch [mm])	Max Operating Pressure	Temperature Range	ANSI #125/#150 Flange Compatibility ²		Fully Closed Leakage (DP = 2"wc [0.5 kPa])
VKF10.032	Swing Thru	1.26 [32]	21.8 psig [1.5 bar]	5 to 356°F ¹ [-15 to 180°C]	1-1/4"	1-1/2"	Less than 2.0% of full open flow
VKF10.040		1.57 [40]			1-1/2"	2"	
VKF10.050		1.97 [50]			2"	2-1/2"	
VKF10.065		2.56 [65]			2-1/2"	3"	
VKF10.080		3.15 [80]			3"	4"	
VKF10.100		3.94 [100]			4"	5"	
VKF10.125		14.5 psig [1 bar]	4.92 [125]		5"	6"	
VKF10.150			5.91 [150]		6"	8"	
VKF10.200			7.87 [200]		8"		
VKF11.032	Beveled Disk	1.26 [32]	21.8 psig [1.5 bar]	5 to 356°F ¹ [-15 to 180°C]	1-1/4"	1-1/2"	Less than 0.5% of full open flow
VKF11.040		1.57 [40]			1-1/2"	2"	
VKF11.050		1.97 [50]			2"	2-1/2"	
VKF11.065		2.56 [65]			2-1/2"	3"	
VKF11.080		3.15 [80]			3"	4"	
VKF11.100		3.94 [100]			4"	5"	
VKF11.125		14.5 psig [1 bar]	4.92 [125]		5"	6"	
VKF11.150			5.91 [150]		6"	8"	
VKF11.200			7.87 [200]		8"		

¹ For gas service (natural gas, propane, etc.), the temperature range is 5 to 140°F [-15 to 60°C].

² See Mounting Flange Notes on page 2 for important information on flange compatibility.

Table 2. Fitment of Full Port and Reduced Port Valves

ANSI #125/#150 Flange Size	Swing Thru		Beveled Disk	
	Full Port	Reduced Port	Full Port	Reduced Port
1-1/4"	VKF10.032	X	VKF11.032	X
1-1/2"	VKF10.040	VKF10.032	VKF11.040	VKF11.032
2"	VKF10.050	VKF10.040	VKF11.050	VKF11.040
2-1/2"	VKF10.065	VKF10.050	VKF11.065	VKF11.050
3"	VKF10.080	VKF10.065	VKF11.080	VKF11.065
4"	VKF10.100	VKF10.080	VKF11.100	VKF11.080
5"	VKF10.125	VKF10.100	VKF11.125	VKF11.100
6"	VKF10.150	VKF10.125	VKF11.150	VKF11.125
8"	VKF10.200	VKF10.150 ¹	VKF11.200	VKF11.150 ¹

¹ 8" butt-weld flanges and 6" full-face gaskets with bolt holes must be used when fitting a 6" valve between two 8" flanges. See "Mounting flange notes" on page 2

Features	The valve disk does not close against an end stop.
VKF10.xxx models	After mounting the actuator, the position indicator and valve disk are both at 5°.
VKF11.xxx models	The valve disk closes against an end stop (approx. 5° position).

Ordering information	The butterfly valve and actuator are ordered as individual items.
	<i>Example:</i>
	1 VKF10.100 butterfly valve
	1 SQM40.255R11 actuator
	VAX assemblies include the actuator mounted to the VKF1... butterfly valve and are tested and shipped as a single component. See Technical Instructions VA-3100.

Accessories

SQM33



Actuator
 (to be ordered separately)

Refer to data sheet N7813

SQM40.xx5xxx



Actuator
 (to be ordered separately)

Refer to data sheet N7817

SQM45.295B9



Actuator
 (to be ordered separately)

Refer to data sheet N7814

ASK33.1



SQM33, SQM40, SQM45 mounting bracket
 (included with each VKF1 valve – does not need to be ordered separately!)

- Screws are provided to mount the actuator to the ASK33.1 bracket

SQM5x.xx5xxxx



Actuator
 (to be ordered separately)

- Only SQM5 actuators with the 10mm D shaft may be used with the VKF1 butterfly valves!

Refer to data sheet N7815

ASK33.3



SQM5 mounting bracket
 (to be ordered separately)

- Discard standard mounting bracket ASK33.1
- Screws are provided to mount the SQM5 actuator to the ASK33.3 bracket

Accessories, continued

SQN7x.xxxxx1



Actuator
(to be ordered separately)

Refer to data sheets N7802
and N7804

ASK33.5



SQN7 mounting bracket and reducing
sleeve
(to be ordered separately)

- Discard standard mounting bracket ASK33.1
- Screws are provided to mount the SQN7 actuator to the ASK33.5 bracket

VAx



Valve actuator assemblies

- Includes the valve, coupling, bracket, and actuator and is shipped as a complete assembly

Refer to Technical Instructions VA-3100

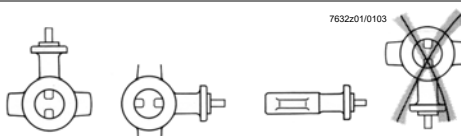
Specifications	Agency approvals/standards	Applicable regulations:	
Approvals		Gas Appliances Regulation	2016/426
		Compliance with the regulations of the applied directives is verified by the adherence to the following standards/regulations: Safety and control devices for burners and appliances burning gaseous and/or liquid fuels – General requirements DIN EN 13611 Safety and control devices for gas burners and gas-burning appliances – General requirements ISO 23550	
Storage environment	DIN EN 60721-3-1 Climatic conditions Mechanical conditions Temperature range Humidity	Class 1K3 Class 1M2 -4 to 140°F [-20 to 60°C] < 95% r.h.	
Operating environment	DIN EN 60721-3-3 Climatic conditions Mechanical conditions Temperature range Humidity	Class 3K5 Class 3M2 5 to 356°F [-15 to 180°C] (air and flue gas) 5 to 140°F [-15 to 60°C] (gas) < 95% r.h.	
Transport environment	DIN EN 60721-3-2 Climatic conditions Mechanical conditions Temperature range Humidity	Class 2K2 Class 2M2 -4 to 140°F [-20 to 60°C] < 95% r.h.	
Permissible mounting positions			
Operating pressure	<ul style="list-style-type: none"> Sizes up to and including 4" [DN100] Sizes 5" [DN125] to 8" [DN200] 	Maximum Pressure	21.8 psig [1.5 bar] 14.5 psig [1 bar]
Types of gases	<ul style="list-style-type: none"> Air Natural gas Propane Butane Dry biogas – maximum concentration 1% H₂S, 1% NH₃ FGR – see temperature limits 		

Specifications, continued

Leakage rate	For VKF10/VKF11 – fully closed	See Table 5
---------------------	--------------------------------	-------------

Rotation angle	Closed position	5°
	Open position	85°
	Operating stroke	80°

Valve stem rotates clockwise to open the valve – viewed with shaft pointed at observer

Physical characteristics

Body materials:

- Valve body
GGG40.3
Cast iron with nodular graphite
according to DIN EN 1563
- Shaft and valve disk
Stainless steel
- Shaft seal
Double O-rings
- Bearings
High-temp plastic

Weight
Refer to *Dimensions*



CAUTION:

Condensation, formation of ice, and accumulation of water inside the valve are not permitted.

Flow Data (continued)

Flow rate (SCFH) through the valve body can be estimated using the equation below and the C_v values from Table 3 or 5.

$$Q = 1360 \times C_v \times \left(\sqrt{\frac{P_1 + P_2}{GT_f}} \right) \times \left(\sqrt{\frac{P_1 - P_2}{2}} \right)$$

...where...

C_v = Flow coefficient (see Table 3 or 5)

G = Specific gravity of gas (see Table 6)

P_1 = Absolute inlet pressure in PSIA (PSIG + 14.7)

P_2 = Absolute outlet pressure in PSIA (PSIG + 14.7)

Q = Flow rate in SCFH

T_f = Media temperature in degrees Rankine ($^{\circ}\text{F} + 460$)

Once the flow rate is calculated in SCFH, this value can be multiplied by the Higher Heating Value (HHV) to obtain the heat input for a given flow rate.

Table 6: Gas Properties

Type of Gas	Specific Gravity (S.G.)	Higher Heating Value (HHV) - BTU/SCF
Air	1.00	-
Natural Gas	0.64	1000
Propane	1.52	2500
Butane	2.00	3200
Digester Gas*	0.84	550
FGR**	1.00	-

* The S.G. and HHV can vary widely depending on the gas source.

** The S.G. of FGR can be approximated to be 1.
Compensate for higher temperatures with equation above.

Actuator Torque

Table 7: Torque Required to Operate VKF1 Valves at Various Differential Pressures (in-lb)

Part Number	Valve Size	Pressure Drop Across Valve (PSI)					
		0.5	1	5	10	15	20
VKF1x.032	1-1/4"	3	3	5	6	8	9
VKF1x.040	1-1/2"	3	3	5	6	8	9
VKF1x.050	2"	3	3	5	6	8	9
VKF1x.065	2-1/2"	3	4	6	8	11	13
VKF1x.080	3"	3	4	7	10	14	17
VKF1x.100	4"	3	4	11	19	30	36
VKF1x.125	5"	3	5	15	27	40	-
VKF1x.150	6"	5	7	22	41	60	-
VKF1x.200	8"	5	9	39	76	114	-

Dimensions

Dimensions in inches [mm]

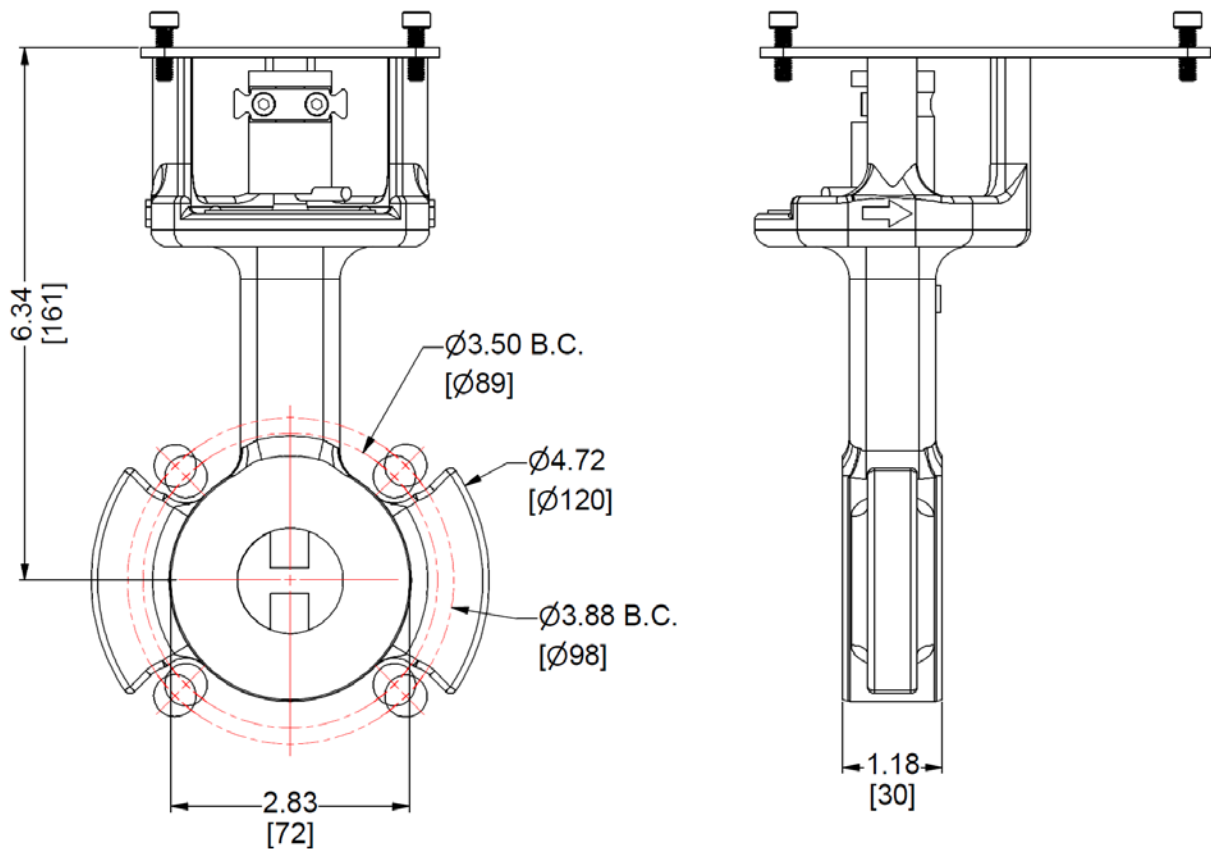
VKF1x.032 – 1-1/4" valve

Weight: 5.1 lb [2.3 kg]

Table 8: Recommended Bolts for Mounting VKF1x.032 Valves between Flanges

Flange Size	Application	Nominal Diameter	Length ¹	Quantity
1-1/4"	Full port	1/2"	3-1/2"	4
1-1/2"	Reduced port	1/2"	3-3/4"	4

¹ Bolt lengths are calculated assuming the VKF1 valve is being mounted between two 125#/150# ANSI flanges, with two 1/16" thick gaskets, two SAE washers, and one standard hex nut

Dimensions (continued)

Dimensions in inches [mm]

VKF1x.040 – 1-1/2" valve

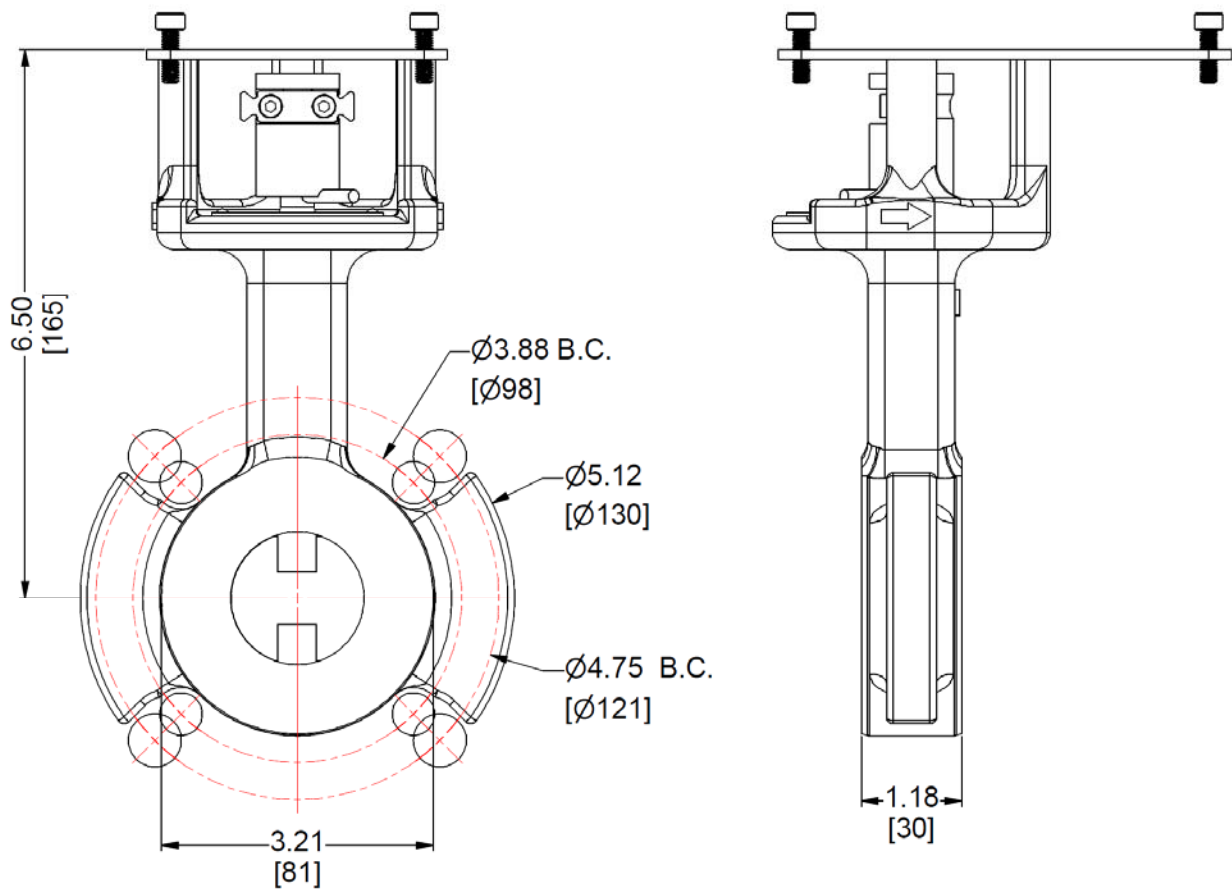

Weight: 5.5 lb [2.5 kg]

Table 9: Recommended Bolts for Mounting VKF1x.040 Valves between Flanges

Flange Size	Application	Nominal Diameter	Length ¹	Quantity
1-1/2"	Full port	1/2"	3-3/4"	4
2"	Reduced port	5/8"	4"	4

¹ Bolt lengths are calculated assuming the VKF1 valve is being mounted between two 125#/150# ANSI flanges, with two 1/16" thick gaskets, two SAE washers, and one standard hex nut

Dimensions (continued)

Dimensions in inches [mm]

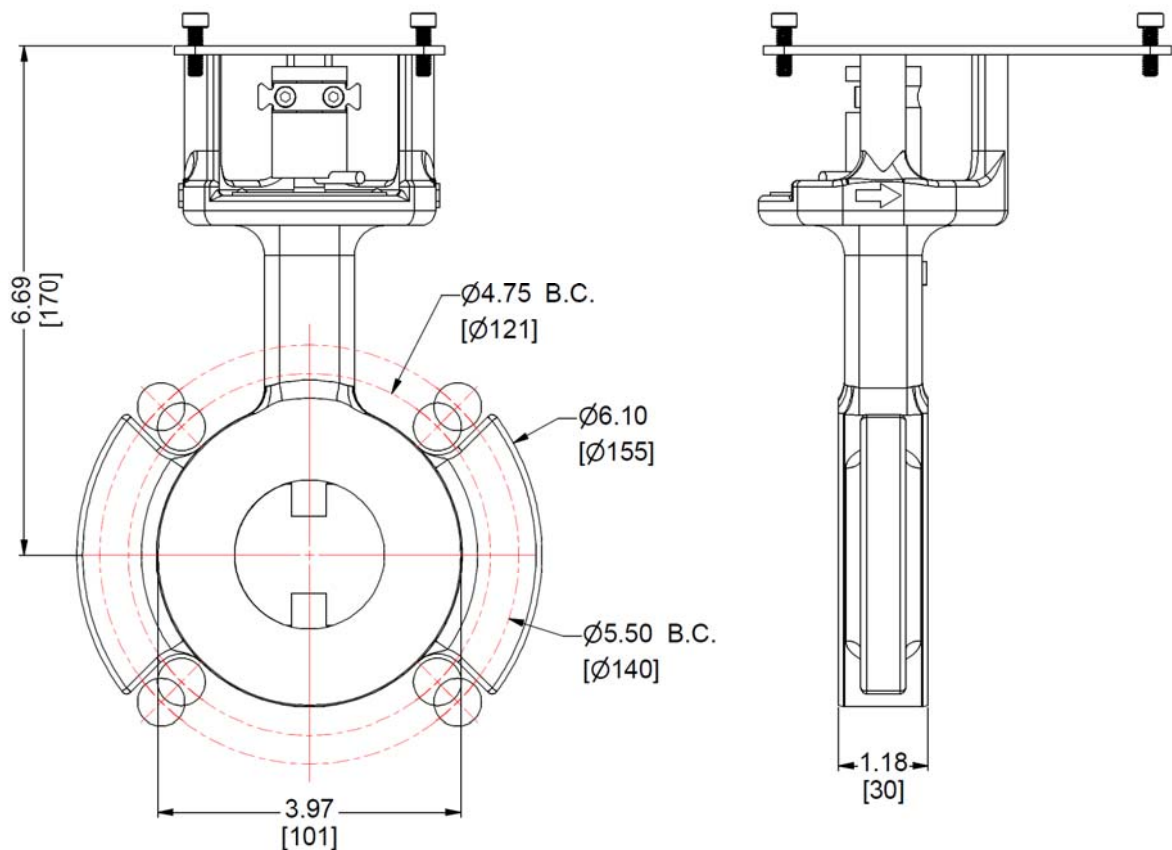
VKF1x.050 – 2" valve

Weight: 6.4 lb [2.9 kg]

Table 10: Recommended Bolts for Mounting VKF1x.050 Valves between Flanges

Flange Size	Application	Nominal Diameter	Length ¹	Quantity
2"	Full port	5/8"	4"	4
2-1/2"	Reduced port	5/8"	4-1/4"	4

¹ Bolt lengths are calculated assuming the VKF1 valve is being mounted between two 125#/150# ANSI flanges, with two 1/16" thick gaskets, two SAE washers, and one standard hex nut

Dimensions (continued)

Dimensions in inches [mm]

VKF1x.065 – 2-1/2" valve

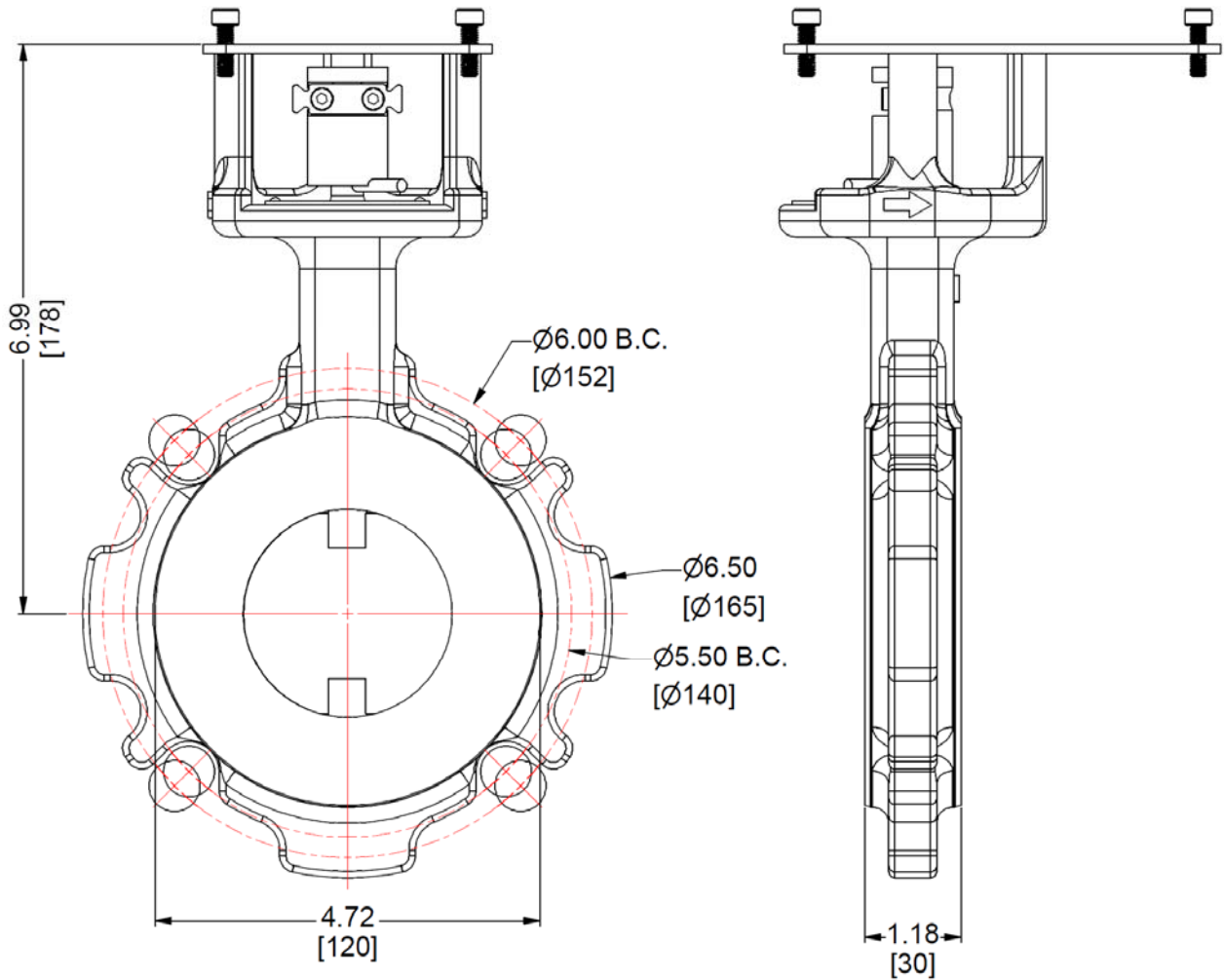

Weight: 7.5 lb [3.4 kg]

Table 11: Recommended Bolts for Mounting VKF1x.065 Valves between Flanges

Flange Size	Application	Nominal Diameter	Length ¹	Quantity
2-1/2"	Full port	5/8"	4-1/4"	4
3"	Reduced port	5/8"	4-1/4"	4

¹ Bolt lengths are calculated assuming the VKF1 valve is being mounted between two 125#/150# ANSI flanges, with two 1/16" thick gaskets, two SAE washers, and one standard hex nut

Dimensions (continued)

Dimensions in inches [mm]

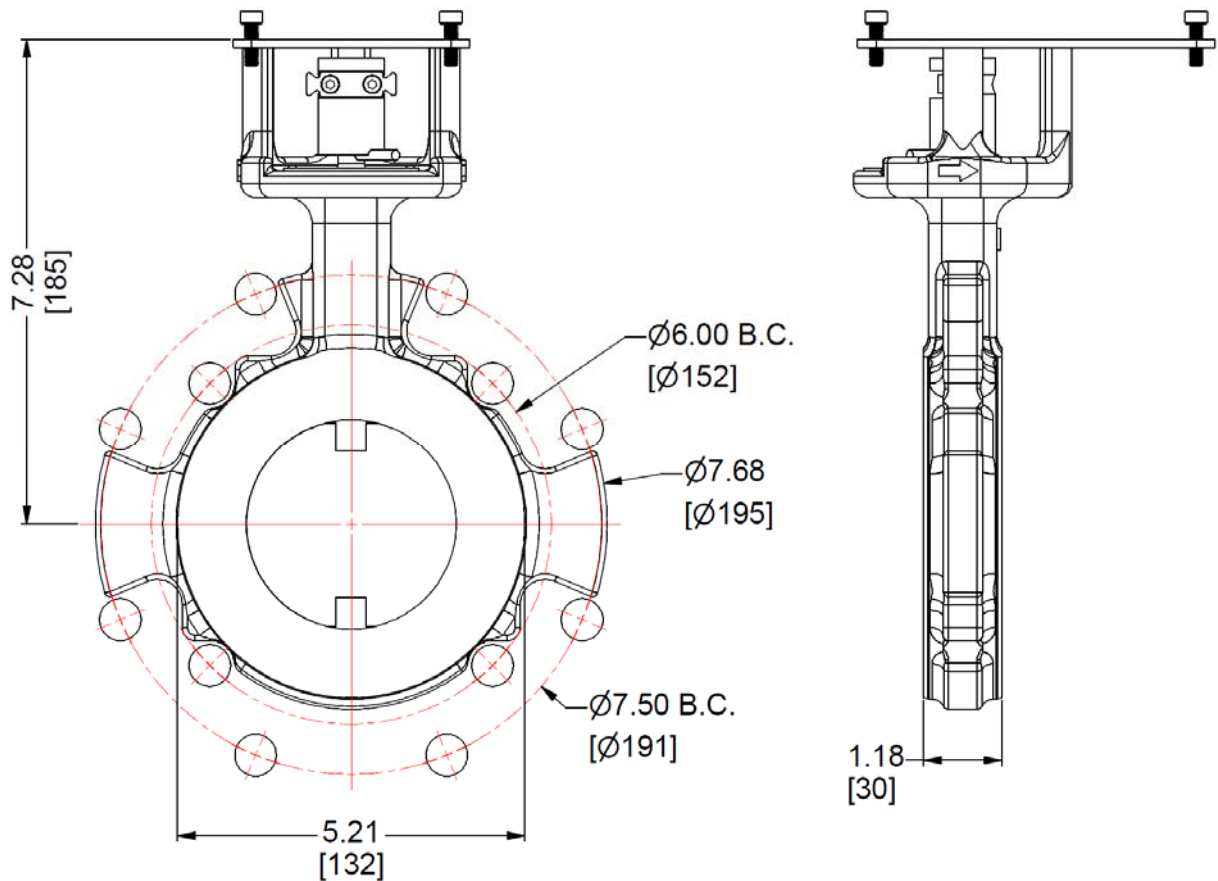
VKF1x.080 – 3" valve

Weight: 7.9 lb [3.6 kg]

Table 12: Recommended Bolts for Mounting VKF1x.080 Valves between Flanges

Flange Size	Application	Nominal Diameter	Length ¹	Quantity
3"	Full port	5/8"	4-1/4"	4
4"	Reduced port	5/8"	4-1/4"	8

¹ Bolt lengths are calculated assuming the VKF1 valve is being mounted between two 125#/150# ANSI flanges, with two 1/16" thick gaskets, two SAE washers, and one standard hex nut

Dimensions (continued)

Dimensions in inches [mm]

VKF1x.100 – 4" valve

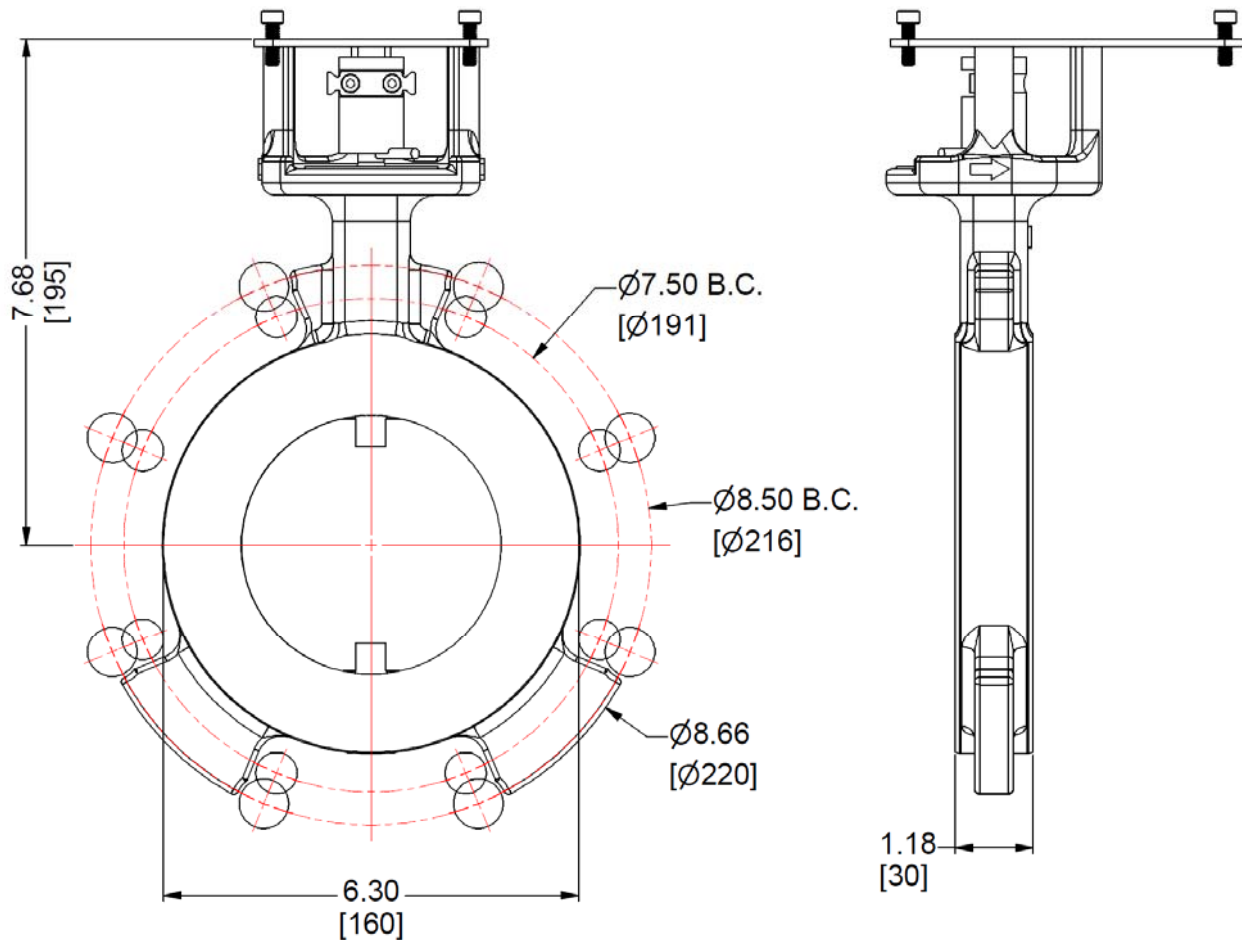

Weight: 9.5 lb [4.3 kg]

Table 13: Recommended Bolts for Mounting VKF1x.100 Valves between Flanges

Flange Size	Application	Nominal Diameter	Length ¹	Quantity
4"	Full port	5/8"	4-1/4"	8
5"	Reduced port	3/4"	4-1/2"	8

¹ Bolt lengths are calculated assuming the VKF1 valve is being mounted between two 125#/150# ANSI flanges, with two 1/16" thick gaskets, two SAE washers, and one standard hex nut

Dimensions (continued)

Dimensions in inches [mm]

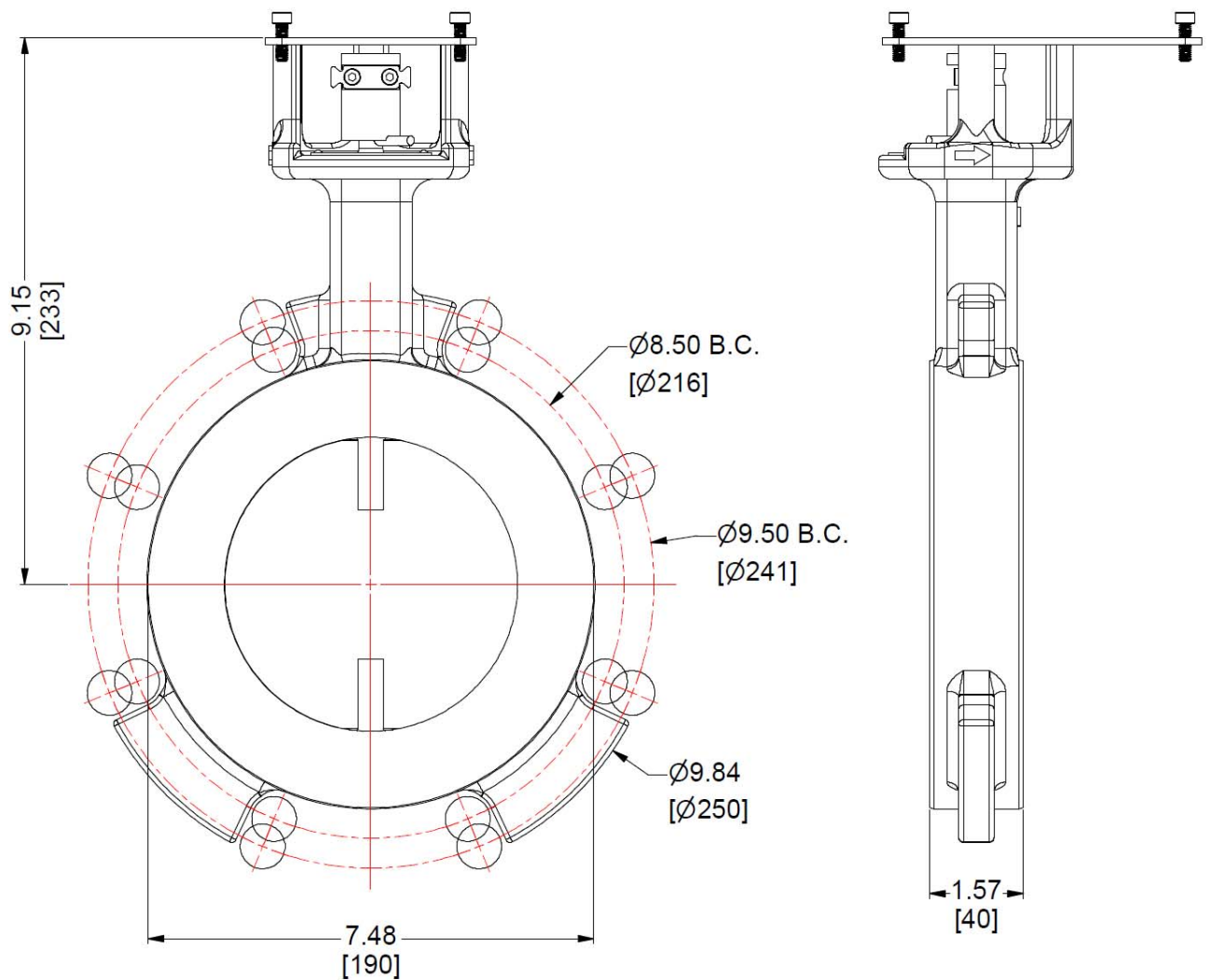
VKF1x.125 – 5" valve

Weight: 16.7 lb [7.6 kg]

Table 14: Recommended Bolts for Mounting VKF1x.125 Valves between Flanges

Flange Size	Application	Nominal Diameter	Length ¹	Quantity
5"	Full port	3/4"	5"	8
6"	Reduced port	3/4"	5"	8

¹ Bolt lengths are calculated assuming the VKF1 valve is being mounted between two 125#/150# ANSI flanges, with two 1/16" thick gaskets, two SAE washers, and one standard hex nut

Dimensions (continued)

Dimensions in inches [mm]

VKF1x.150 – 6" valve

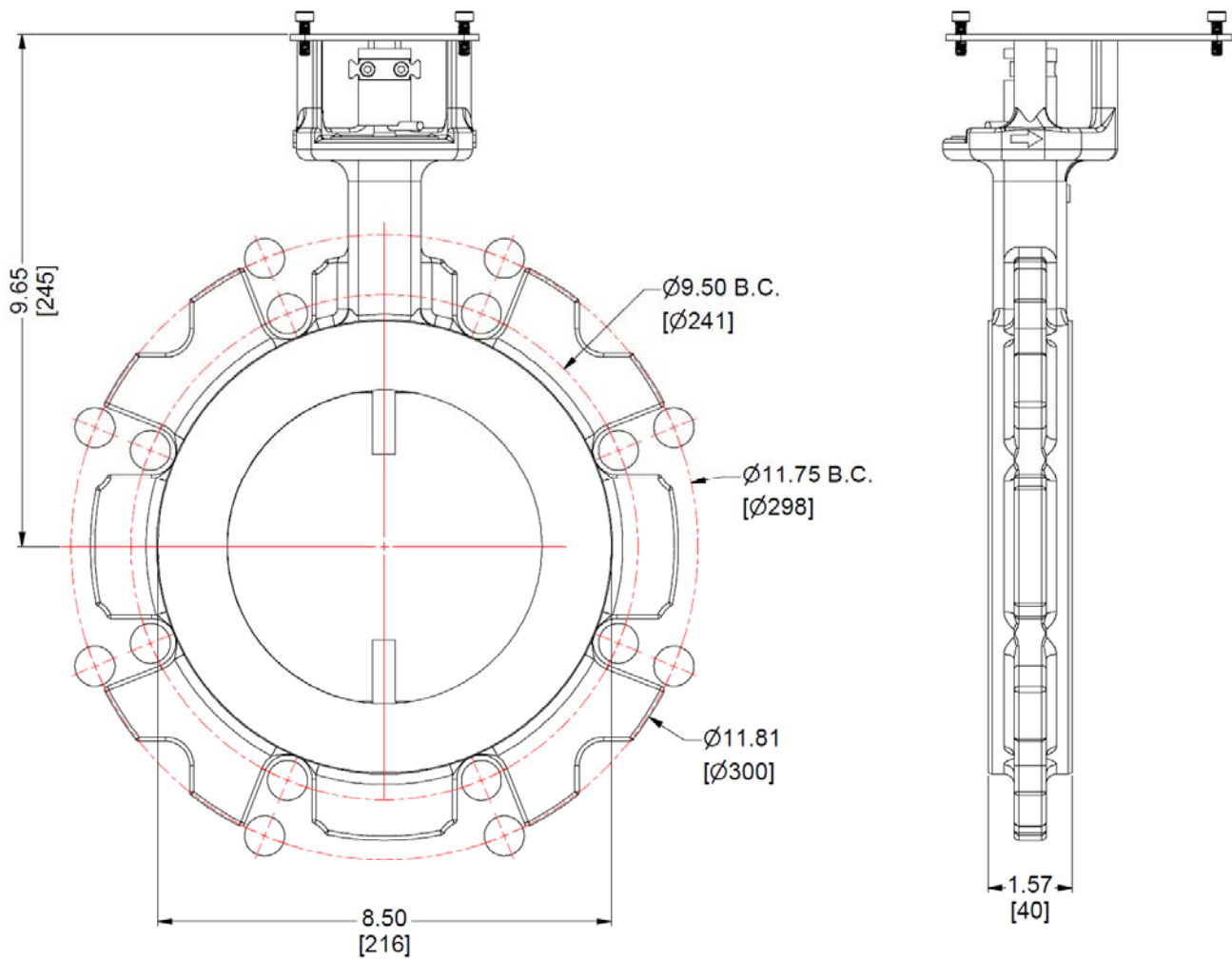

Weight: 21.1 lb [9.6 kg]

Table 15: Recommended Bolts for Mounting VKF1x.150 Valves between Flanges

Flange Size	Application	Nominal Diameter	Length ¹	Quantity
6"	Full port	3/4"	5"	8
8"	Reduced port ²	3/4"	5-1/4"	8

¹ Bolt lengths are calculated assuming the VKF1 valve is being mounted between two 125#/150# ANSI flanges, with two 1/16" thick gaskets, two SAE washers, and one standard hex nut

² When using a 6" VKF1x.150 valve as a reduced port valve, 8" butt-weld flanges and 6" full-face gaskets with bolt holes must be used. See "Mounting flange notes" on page 2 for a more detailed explanation.

Dimensions (continued)
 Dimensions in inches [mm]

VKF1x.200 – 8” valve

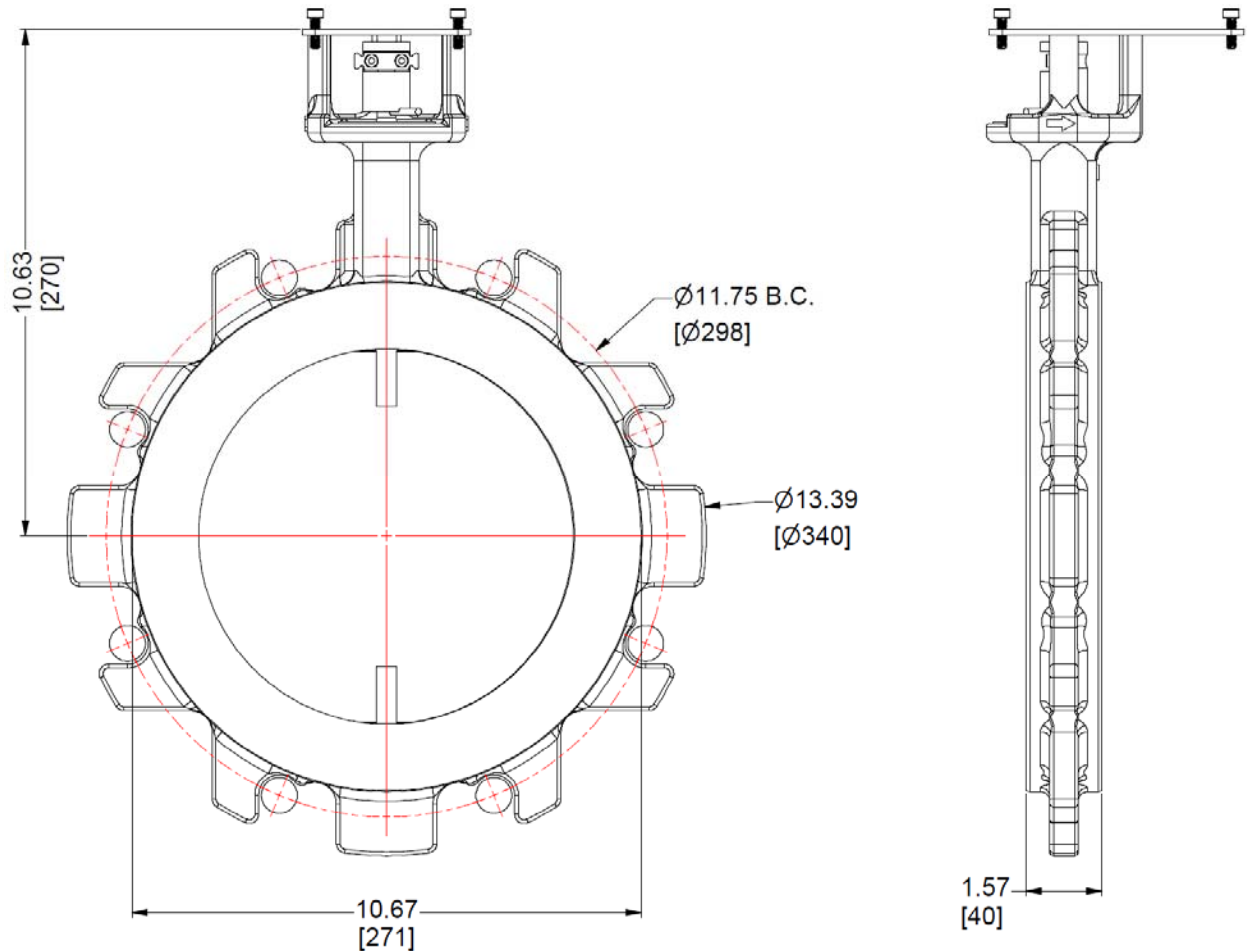

Weight: 28.2 lb [12.8 kg]

Table 16: Recommended Bolts for Mounting VKF1x.200 Valves between Flanges

Flange Size	Application	Nominal Diameter	Length ¹	Quantity
8"	Full port	3/4"	5-1/4"	8

¹ Bolt lengths are calculated assuming the VKF1 valve is being mounted between two 125#/150# ANSI flanges, with two 1/16" thick gaskets, two SAE washers, and one standard hex nut

Information in this publication is based on current specifications. The company reserves the right to make changes in specifications and models as design improvements are introduced. Other product or company names mentioned herein may be the trademarks of their respective owners.

Siemens AG Smart Infrastructure
 Berliner Ring 23
 76437 Rastatt
 GERMANY

Your feedback is important to us. If you have comments about this document, please send them to techsupport@SCCcombustion.com

Document No. CC1N7673us
 Country of Origin: DE